

Turmdrehkran

34 K

Tower Crane / Grue à tour / Gru a torre
Grúa torre / Guindaste de torre

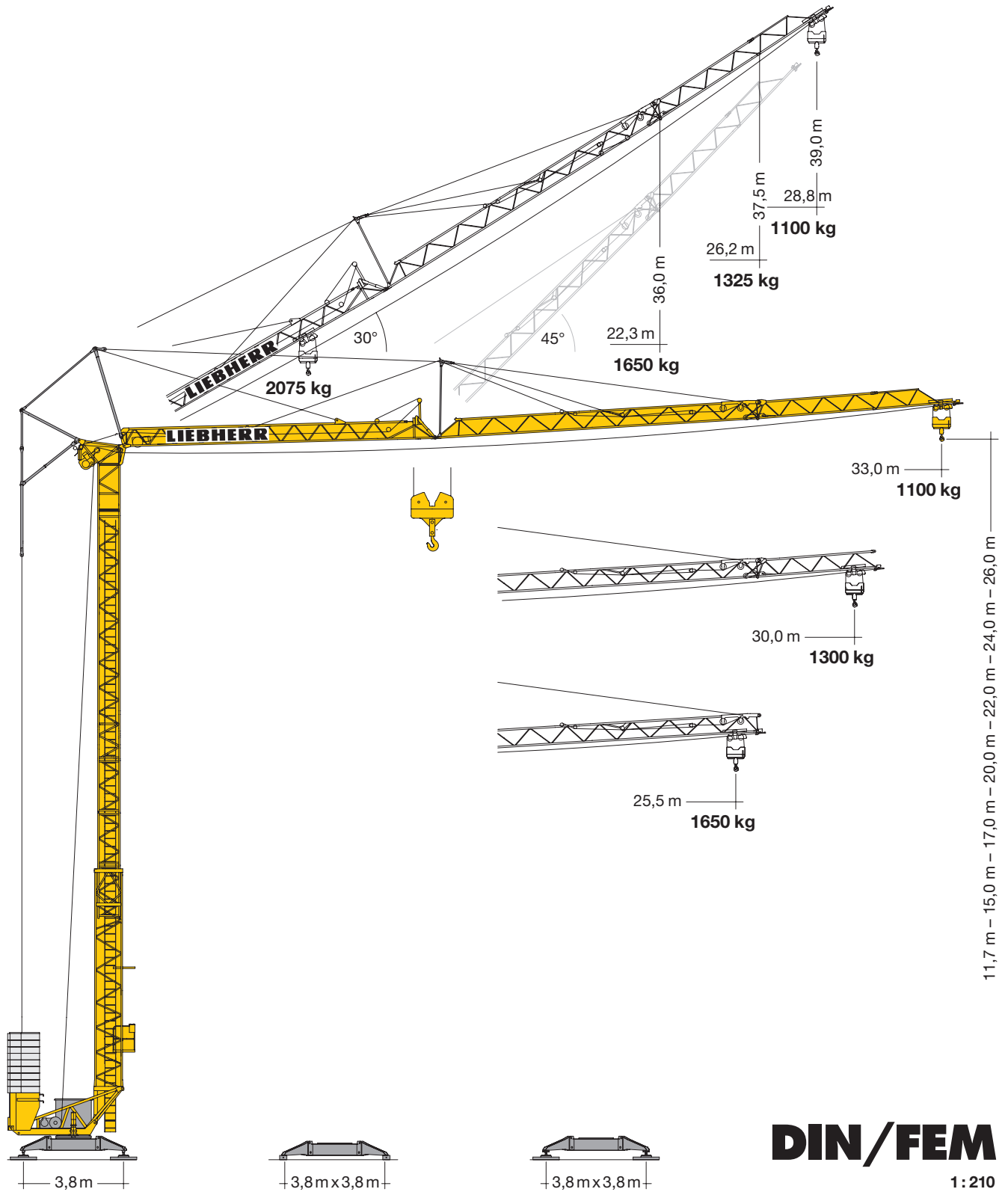

LIEBHERR

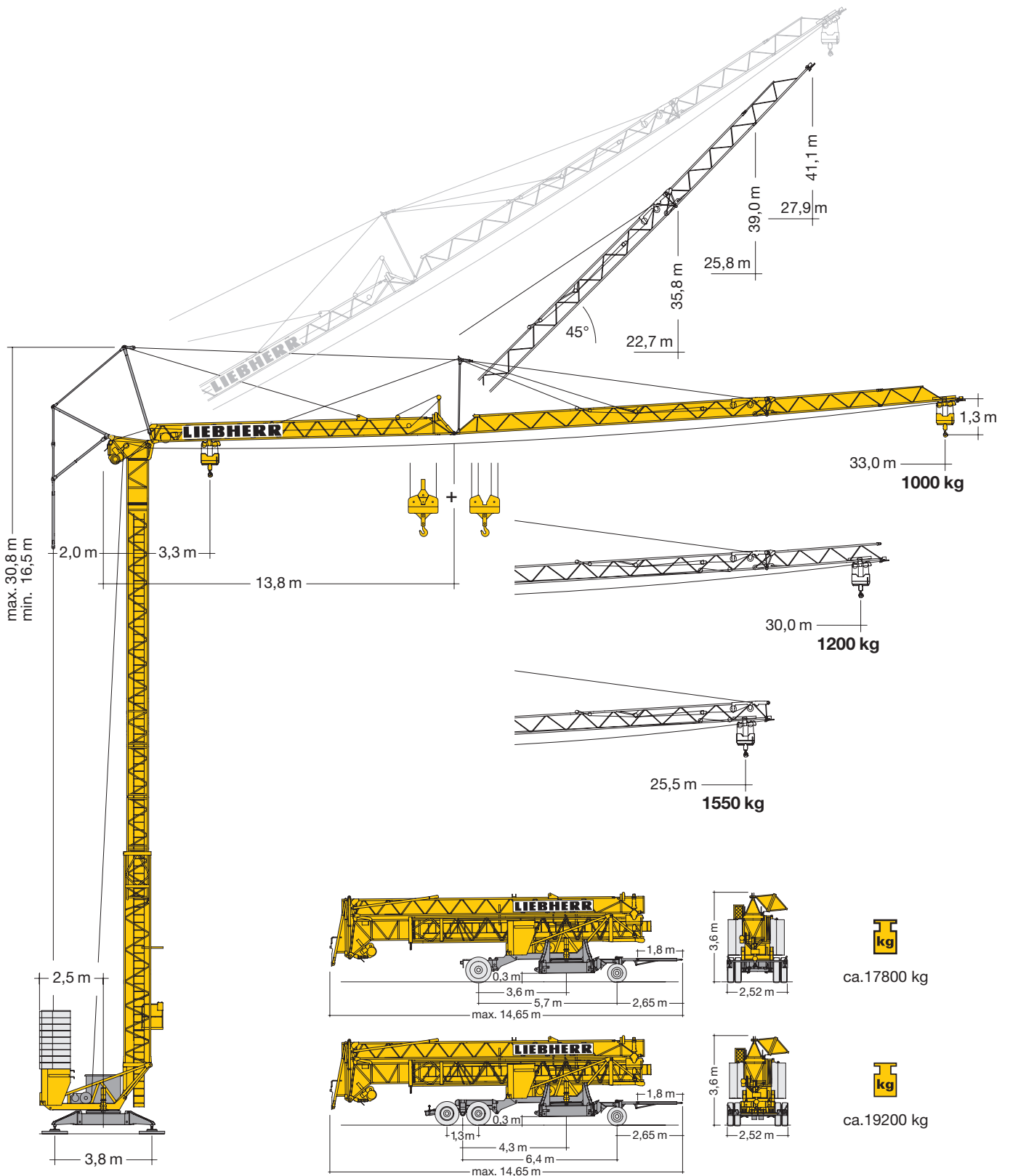

Gewicht

Weight / Poids / Peso / Peso / Pesos

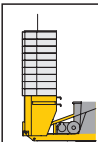

r = 2,5 m 18980 kg



ca. 10400 kg
(26 m: + 1050 kg)

Ausladung und Tragfähigkeit

Radius and capacity / Portée et charge / Sbraccio e portata / Alcances y cargas / Alcance e capacidade de carga

| m | max. kg m/kg | m/kg | | | | | | | | | | | | | | | | | | | | | | | |
|------|---------------------|------|------|------|------|------|------|------|------|------|------|------|------|------|------|------|------|------|------|------|------|------|------|------|------|
| | | 10,0 | 11,0 | 12,0 | 13,0 | 14,0 | 15,0 | 16,0 | 17,0 | 18,0 | 19,0 | 20,0 | 21,0 | 22,0 | 23,0 | 24,0 | 25,5 | 26,0 | 27,0 | 28,0 | 29,0 | 30,0 | 31,0 | 32,0 | 33,0 |
| 33,0 | 3,3 - 17,40 2075 | 2075 | 2075 | 2075 | 2075 | 2075 | 2075 | 2075 | 2075 | 1990 | 1870 | 1750 | 1650 | 1560 | 1480 | 1410 | 1310 | 1275 | 1220 | 1160 | 1120 | 1100 | 1100 | 1100 | 1100 |
| 30,0 | 3,3 - 18,40 2075 | 2075 | 2075 | 2075 | 2075 | 2075 | 2075 | 2075 | 2075 | 2075 | 2000 | 1880 | 1770 | 1680 | 1590 | 1510 | 1400 | 1370 | 1310 | 1300 | 1300 | 1300 | 1300 | 1300 | 1300 |
| 25,5 | 3,3 - 19,50 2075 | 2075 | 2075 | 2075 | 2075 | 2075 | 2075 | 2075 | 2075 | 2075 | 2075 | 2010 | 1890 | 1790 | 1700 | 1650 | 1650 | | | | | | | | |

| m | max. kg m/kg | m/kg | | | | | | | | | | | | | | | | | | | | | | | |
|------|---------------------|------|------|------|------|------|------|------|------|------|------|------|------|------|------|------|------|------|------|------|------|------|------|------|------|
| | | 10,0 | 11,0 | 12,0 | 13,0 | 14,0 | 15,0 | 16,0 | 17,0 | 18,0 | 19,0 | 20,0 | 21,0 | 22,0 | 23,0 | 24,0 | 25,5 | 26,0 | 27,0 | 28,0 | 29,0 | 30,0 | 31,0 | 32,0 | 33,0 |
| 33,0 | 3,3 - 17,06 2000 | 2000 | 2000 | 2000 | 2000 | 2000 | 2000 | 2000 | 2000 | 1870 | 1750 | 1640 | 1740 | 1450 | 1370 | 1300 | 1200 | 1170 | 1110 | 1060 | 1010 | 1000 | 1000 | 1000 | 1000 |
| 30,0 | 3,3 - 18,10 2000 | 2000 | 2000 | 2000 | 2000 | 2000 | 2000 | 2000 | 2000 | 2000 | 1880 | 1770 | 1660 | 1560 | 1480 | 1400 | 1300 | 1270 | 1210 | 1200 | 1200 | 1200 | 1200 | 1200 | 1200 |
| 25,5 | 3,3 - 19,19 2000 | 2000 | 2000 | 2000 | 2000 | 2000 | 2000 | 2000 | 2000 | 2000 | 1900 | 1790 | 1690 | 1600 | 1550 | 1550 | | | | | | | | | |

| m | max. kg m/kg | m/kg | | | | | | | | | | | | | | | | | | | | | | | |
|------|---------------------|------|------|------|------|------|------|------|------|------|------|------|------|------|------|------|------|------|------|------|------|------|------|------|------|
| | | 10,0 | 11,0 | 12,0 | 13,0 | 14,0 | 15,0 | 16,0 | 17,0 | 18,0 | 19,0 | 20,0 | 21,0 | 22,0 | 23,0 | 24,0 | 25,5 | 26,0 | 27,0 | 28,0 | 29,0 | 30,0 | 31,0 | 32,0 | 33,0 |
| 33,0 | 3,3 - 9,91 4000 | 3950 | 3490 | 3120 | 2820 | 2570 | 2350 | 2170 | 2010 | 2000 | 2000 | 1890 | 1780 | 1680 | 1590 | 1510 | 1400 | 1360 | 1300 | 1240 | 1180 | 1130 | 1090 | 1040 | 1000 |
| 30,0 | 3,3 - 10,46 4000 | 4000 | 3750 | 3350 | 3030 | 2760 | 2530 | 2400 | 2400 | 2280 | 2130 | 2000 | 1880 | 1780 | 1680 | 1590 | 1510 | 1440 | 1370 | 1310 | 1250 | 1200 | 1200 | 1200 | 1200 |
| 25,5 | 3,3 - 11,04 4000 | 4000 | 4000 | 3600 | 3250 | 3100 | 2990 | 2760 | 2560 | 2390 | 2230 | 2100 | 1970 | 1860 | 1760 | 1670 | 1550 | | | | | | | | |

| m | max. kg m/kg | Auslegerstellung 30° / Elevated jib 30° / Flèche inclinée 30° m/kg Braccio inclinato a 30° / Pluma inclinada 30° / Lança inclinada 30° | | | | | | | | | | | | | |
|------|---------------------|---|------|------|------|------|------|------|------|------|------|------|------|------|------|
| | | 16,0 | 17,0 | 18,0 | 19,0 | 20,0 | 21,0 | 22,3 | 23,0 | 24,0 | 25,0 | 26,2 | 27,0 | 28,0 | 28,8 |
| 33,0 | 3,0 - 16,48 2075 | 2075 | 2000 | 1850 | 1730 | 1620 | 1520 | 1400 | 1350 | 1280 | 1210 | 1140 | 1100 | 1100 | 1100 |
| 30,0 | 3,0 - 17,15 2075 | 2075 | 2075 | 1950 | 1820 | 1710 | 1600 | 1480 | 1430 | 1350 | 1325 | 1325 | | | |
| 25,5 | 3,0 - 17,76 2075 | 2075 | 2075 | 2040 | 1910 | 1790 | 1680 | 1650 | | | | | | | |

Antriebe

Driving units / Mécanismes d'entraînement / Azionamenti / Mecanismos / Mecanismos

| | | |
|--|---|--------------|
| | U/min. 0 ↔ 0,9 sl./min tr./min | 2,2 kW EDC |
| | 20,0 / 40,0 m/min | 1,3 / 2,3 kW |
| | 25,0 m/min | 2 x 1,3 kW |
| | 0 - 45° ca. 30 sec. | 2,2 kW |

| | Stufe / Step / Cran Marcia / Velocidad Velocidade | kg | m/min | |
|----------------|---|--------------|--------------|-------|
| | | | kg | m/min |
| 11,0 kW | 1 | 2075 | 6,0 | |
| | 2 | 2075 | 25,0 | |
| | 3 | 1075 | 50,0 | |
| 11,0 kW | 1 | 2000 4000 | 6,0 3,0 | |
| | 2 | 2000 4000 | 25,0 12,5 | |
| | 3 | 1000 2000 | 50,0 25,0 | |
| 11,0 kW FU | 1 | 2000 4000 | 3,0 1,5 | |
| | 2 | 2000 4000 | 30,0 15,0 | |
| | 3 | 1500 3000 | 40,0 20,0 | |
| | 4 | 1000 2000 | 55,0 27,5 | |





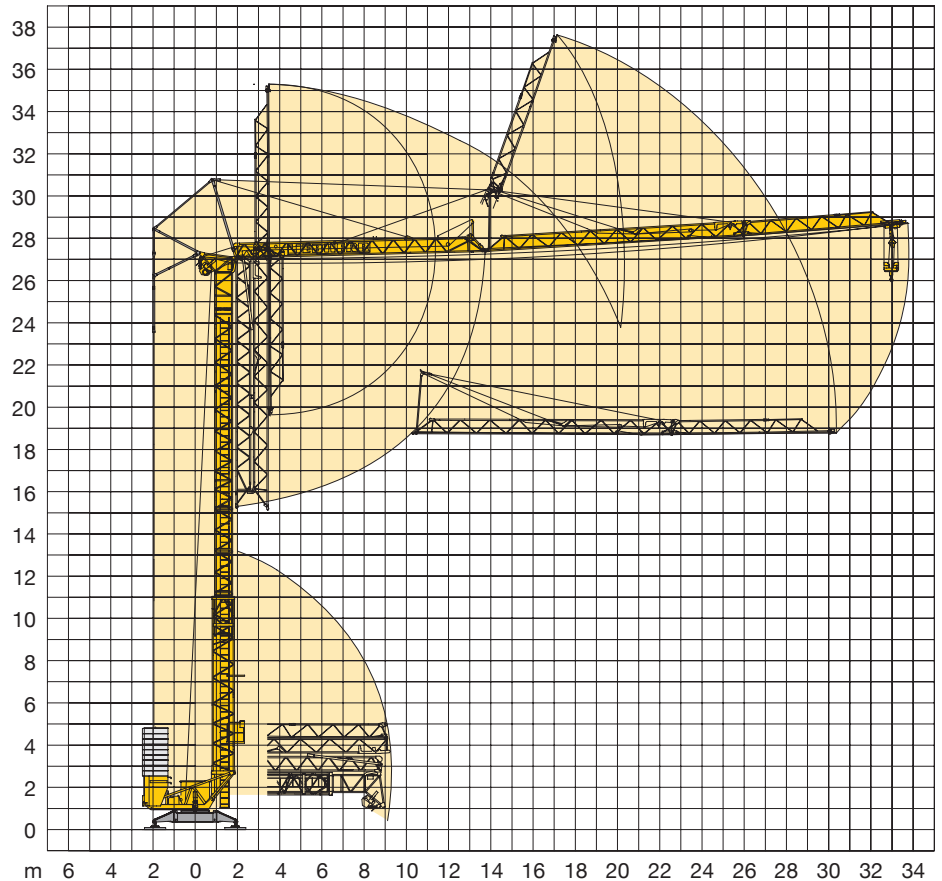



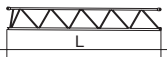

| | | | | |
|-----|--|-------------|--|--------------|
| BGL | | C.0.08.0040 | | C.0.08.035,5 |
|-----|--|-------------|--|--------------|

| | 400 V | Hz | kVA |
|--------|--|----|--------------------|
| 78,0 m | 4 x 6 mm ² KL 4 x 6 mm ² FU | 50 | 22,0 KL 17,0 FU |

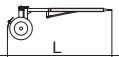

Kolli-Liste

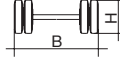
Packing List / Liste de colisage / Lista dei colli / Lista de contenido / Lista de embalagem

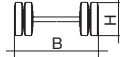
| Pos. Item Rep. Voce Pos. Ref. | Anz. Qty. Qte. Qta. Cant. Cant. | | | L (m) | B (m) | H (m) | kg | |
|--|--|--|---|---|-------|-------|------|------|
| 1 | 3 | Turmstück / Tower section Elément de mât / Elemento de torre Tramo de torre / Peça de torre |  |  | 2,10 | 0,85 | 0,88 | 350 |
| 2 | 1 | Ausleger-Verlängerung 25,5 m – 30,0 m Jib extension / Rallonge de la flèche Elemento estensione braccio Prolongación de pluma / Extensão da lança |  |  | 4,70 | 0,80 | 0,70 | 180 |
| 3 | 1 | Ausleger-Verlängerung 30,0 m – 33,0 m Jib extension / Rallonge de la flèche Elemento estensione braccio Prolongación de pluma / Extensão da lança |  |  | 3,10 | 0,80 | 0,70 | 65 |
| 4 | 1 | Transportachse vorne Tra 100 KY 2 Road transport axle front / Essieux de transport avant / Asse di trasporto anteriore / Eje delantero para transporte / Eixo de transporte dianteiro |  |  | 3,00 | 1,13 | 0,97 | 660 |
| 5 | 1 | Transportachse hinten Tra 120 GY 1A Road transport axle behind / Essieux de transport arrière / Asse di trasporto posteriore / Eje trasero para transporte / Eixo de transporte traseiro |  |  | 1,90 | 2,50 | 1,05 | 1150 |
| 6 | 1 | Transportachse Tra 200 GZ 3 / Road transport axle Essieux de transport / Assali par trasporto Tra 200 GZ 3 / Eje de transporte Eixo de transporte |  |  | 3,10 | 2,50 | 1,10 | 2600 |
| 7 | 1 | Kiste mit Seilen und Kleinteilen / Case with ropes and small parts Caisse avec câbles et pièces détachées / Cassa con funi e accessori Caja con cables y piezas sueltas / Caixa contendo cabos e acessórios | | | 1,00 | 0,80 | 1,00 | 450 |

Konstruktionsänderungen vorbehalten!

Subject to alterations! / Sous réserves de modifications!
 Si fa riserva di modifiche! / Salvo modificação da construo!
 ¡Sujeto a modificaciones!

Sämtliche Angaben erfolgen ohne Gewähr. / This information is supplied without liability.

Ces renseignements sont sans garantie. / Le indicazioni contenute si intendono salvo errori ed omissioni.
 Declinamos toda responsabilidad derivada de la información proporcionada. / Declinamos qualquer
 responsabilidade quanto à informação fornecida.

120 P – 3861 H1 B3 DIN 15018 • BGL C.0.08.0040 / FEM (Section 1) Krangruppe A3 und OENORM T3 • 03.01 / 6 Printed in Germany.